



# SONOS PLAY:5

(Formerly S5)  
Product Guide

THIS DOCUMENT CONTAINS INFORMATION THAT IS SUBJECT TO CHANGE WITHOUT NOTICE.

No part of this publication may be reproduced or transmitted in any form or by any means, electronic or mechanical, including but not limited to photocopying, recording, information retrieval systems, or computer network without the written permission of Sonos, Inc.

SONOS and all other Sonos product names and slogans are trademarks or registered trademarks of Sonos, Inc. SONOS Reg. U.S. Pat. & Tm. Off.

Sonos products may be protected by one or more patents. Our patent-to-product information can be found here:

***[sonos.com/legal/patents](http://sonos.com/legal/patents)***

iPhone®, iPod®, iPad® and iTunes® are trademarks of Apple Inc., registered in the U.S. and other countries.

Windows® is a registered trademark of Microsoft Corporation in the United States and other countries.

Android® is a trademark of Google, Inc.

MPEG Layer-3 audio decoding technology licensed from Fraunhofer IIS and Thomson.

Sonos uses MSNTP software, which was developed by N.M. Maclaren at the University of Cambridge.

© Copyright, N.M. Maclaren, 1996, 1997, 2000; © Copyright, University of Cambridge, 1996, 1997, 2000.

All other products and services mentioned may be trademarks or service marks of their respective owners.

©2004-2012 by Sonos, Inc. All rights reserved.

# The SONOS PLAY:5

The SONOS PLAY:5 is a wireless music system that lets you use any Sonos controller (see "Sonos Controllers" on page 2) to control and enjoy all the music you want all over your house.

- Creates room-filling, high-performance sound using a five-way speaker system driven by five digital amplifiers.
- Travels easily— compact size and molded handle make it easy to place the PLAY:5 on the kitchen counter or take it out to the patio with you.
- Works seamlessly with the complete range of Sonos products.

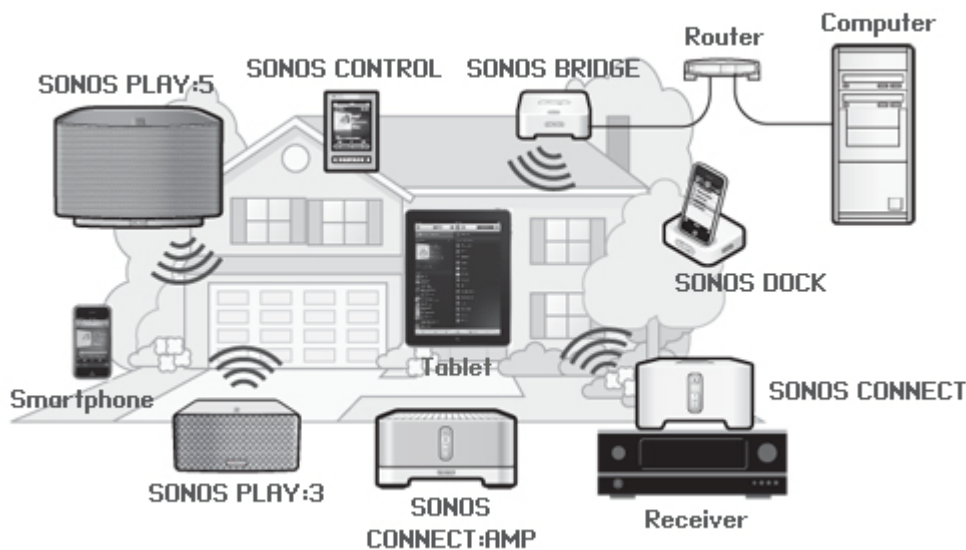

## New to Sonos?

It takes just a few steps to get your Sonos system up and running. See "Your Home Network" on page 2 to make sure your home network is ready for Sonos, and then turn to the Quick Start Guide packaged with your PLAY:5 (formerly S5). Once you've set up your music system, you can add additional Sonos components any time.

**Note:** If you don't plan to listen to music in the room where your broadband router is located, you can connect a SONOS BRIDGE™ (purchased separately) to your router to activate the SonosNet™ wireless mesh network, and place the PLAY:5 wherever you want to listen to music.

## Adding to an existing Sonos system?

The Sonos system can be easily expanded room by room. If you are adding this PLAY:5 to an existing Sonos system, you can turn directly to "Adding to an Existing Sonos System" on page 5.

## Your Home Network

To access Internet music services, Internet radio, and any digital music stored on your computer or Network-Attached Storage (NAS) device, your home network must meet the following requirements:

### Network requirements

**Note:** Your network must have a high-speed Internet connection, as the Sonos system is designed to provide you with online software updates. Your Sonos system must be registered to receive these updates, so be sure to register during the setup process. We do not share your e-mail address with other companies.

- High-speed DSL/Cable modem, or fiber-to-the-home broadband connection for proper playback of Internet-based music services. (If your Internet service provider only offers Satellite Internet access, you may experience playback issues due to fluctuating download rates.)
- If your modem is not a modem/router combination and you want to take advantage of Sonos' automatic online updates, or stream music from an Internet-based music service, **you must install a router in your home network.** If you do not have a router, purchase and install one before proceeding.
  - If you are going to use a Sonos application on an Android™ smartphone, iPhone®, iPod Touch®, iPad® or other tablet, you may need a wireless router in your home network. Please visit our Web site at <http://faq.sonos.com/apps> for more information.
- Connect at least one Sonos component to your home network router using an Ethernet cable, and then you can add other Sonos components wirelessly.
- For best results, you should connect the computer or NAS drive that contains your personal music library collection to your home network router using an Ethernet cable.

### Compatible operating systems

- Windows® XP SP3 and higher
- Macintosh® OS X 10.6 and higher

**Note:** Please visit our Web site at <http://faq.sonos.com/specs> for the latest system requirements, including supported operating system versions.

## Sonos Controllers

You can use any Sonos controller with the SONOS PLAY:5, including:

- The Sonos Controller for Android — Tap the **Market** button on your Android smartphone or tablet to download the free Sonos controller application.
- The Sonos Controller for iPhone or Sonos Controller for iPad — Tap the **App Store** button on your iPhone, iPod touch or iPad to download the free Sonos controller application, or download the application from iTunes®. (If you download from iTunes, you will need to sync before you see the Sonos logo display on your device.)
- The Sonos Controller for Mac or PC. Download from our Website at: [www.sonos.com/support/downloads](http://www.sonos.com/support/downloads).
- The SONOS CONTROL (CR200) or CR100

## SONOS PLAY:5 Front

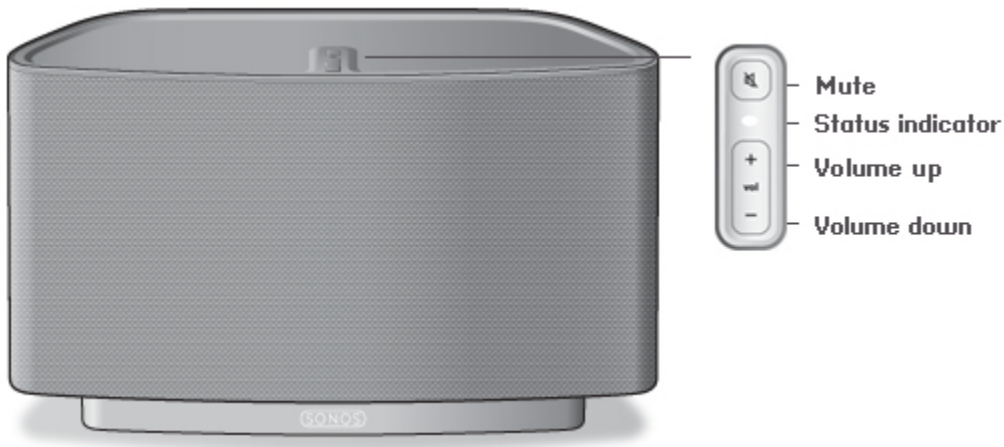

**Note:** The SONOS PLAY:5's front grille is not removable. Tampering with the grille may result in damage to your PLAY:5.

### On/Off

- Using a Sonos controller, select **Pause All** from the **ROOMS** pane (the **Rooms** menu on the **CONTROL**).

Your Sonos system is designed to be always on; the system uses minimal electricity whenever it is not playing music. To quickly stop streaming music in all rooms, you can use the **Pause All** feature to stop the music everywhere.

### Status indicator

- Flashes white when powering up or connecting to your Sonos system.
- Solid white when powered up and connected to your Sonos system (normal operation).

Indicates the current status of that Sonos component. When the Sonos component is in normal operation, you can turn the white status indicator light on and off. For additional information, see the online help system included with your Sonos Controller for Mac or PC.

For a complete list of status indications, please go to <http://faq.sonos.com/led>.

### Mute button

- Lights solid green when sound is muted.
- Flashes green rapidly when household mute or unmute is about to take place.
- Flashes green slowly when Sonos component is connecting to your music system.

To mute/unmute this Sonos component: Press the **Mute** button to mute or unmute this Sonos component.

To mute/unmute all Sonos components: Press and hold the **Mute** button for 3 seconds to mute all Sonos components in your household. Press and hold for 3 seconds to unmute all Sonos components.

### Volume up (+)

### Volume down (-)

Press these buttons to adjust the volume up and down.

## SONOS PLAY:5 Back

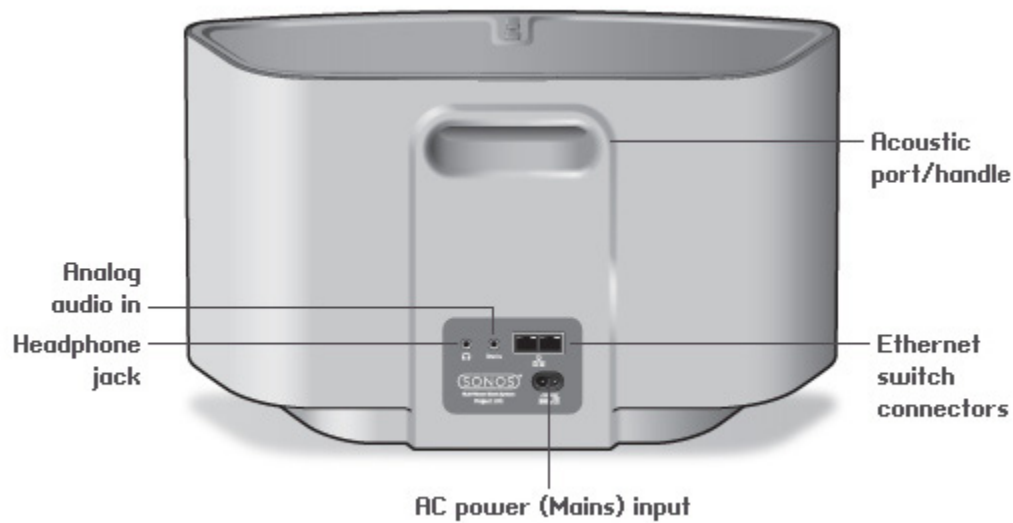

### Acoustic port / handle

The acoustic port doubles as a handle so you can easily lift and carry the PLAY:5 from room to room. Please do not block or obstruct this port when the PLAY:5 is playing music.

### Ethernet switch connectors (2)

Use Category 5 Ethernet cable to connect to a router, computer, or additional network device such as a network-attached storage (NAS) device.

#### LED indicators:

- Flashing Yellow (network activity)
- Green (link connection)

### AC power (mains) input (~100-240 V, 50-60 Hz)

Use the supplied power cord to connect to power outlet.

### 3,5mm (1/8") stereo audio in (2V)

Use the supplied 3,5mm to 3,5mm stereo audio cable to connect the audio outputs from a portable music player to the PLAY:5's analog audio input.

To connect a different audio component, such as a CD player, use a 3,5mm (1/8") mini-stereo to RCA audio cable. Plug the mini-stereo end into the audio input on the S5 and plug the RCA end into the audio outputs on the audio component.

### 3,5mm (1/8") headphone jack

Headphone jack accepts any standard 3,5mm (1/8") headphone plug.

## Selecting a Location for Your PLAY:5

You can position the SONOS PLAY:5 wherever you find the sound most enjoyable. Its compact size and inset handle make it easy to place the PLAY:5 on the kitchen counter, or carry it out to the patio with you. For maximum performance, we have a few guidelines:

- The SONOS PLAY:5 is designed to sound best when placed 3 to 12 inches (8-30 cm) from a wall.
- Place the PLAY:5 across the room from where you will be listening.
- Don't block the acoustic port when in use.
- Locate the PLAY:5 at least 12 inches (30 cm) from a television, computer, or other monitor to avoid the possibility of picture quality interference.
- The PLAY:5 is not water-resistant. Don't leave it outside during a rain storm or position it near water.

## Adding to an Existing Sonos System

Once you've got your Sonos system set up, you can easily add more Sonos components to any room any time (up to 32 rooms).

If your house has structured (built-in) wiring, you can make a wired connection to the additional Sonos components. If you don't have structured wiring, our built-in wireless technology is ideal for you.

1. Select a location for your SONOS PLAY:5 (see "Selecting a Location for Your PLAY:5" for optimal placement guidelines.)
2. Attach the power cord to the PLAY:5, and apply power.
3. If you are making a wireless connection, skip this step and continue on to step 4. If you are making a wired connection, connect a standard Ethernet cable from your router or another Sonos component (or a live network wall plate if you have built-in wiring) to one of the Ethernet switch connections on the back of the new Sonos component.
4. Choose one of the following options:
  - Using a handheld Sonos controller: Select **Add a Sonos Component** from the **Settings** menu and follow the on-screen prompts to add this component to your Sonos system.
  - Using the Sonos Controller for Mac or PC: Select **Add a Sonos Component** from the **Manage** menu and follow the prompts to add this component to your Sonos system.

## Creating a Stereo Pair

The Stereo Pair setting allows you to group two PLAY:3s or two PLAY:5s in the same room to create a wider stereo experience. In this configuration, one unit serves as the left channel and the other serves as the right channel. You cannot combine a PLAY:3 and PLAY:5 unit—the Sonos components in the stereo pair must be the same.

### Optimum placement information

- When creating a stereo pair, it is best to place the two Sonos components 8 to 10 feet away from each other, angled inward to form a triangle with your favorite listening position.

- Your favorite listening position should be 8 to 12 feet from the PLAY:3 or PLAY:5 units. Less distance will increase bass, more distance will improve stereo imaging.

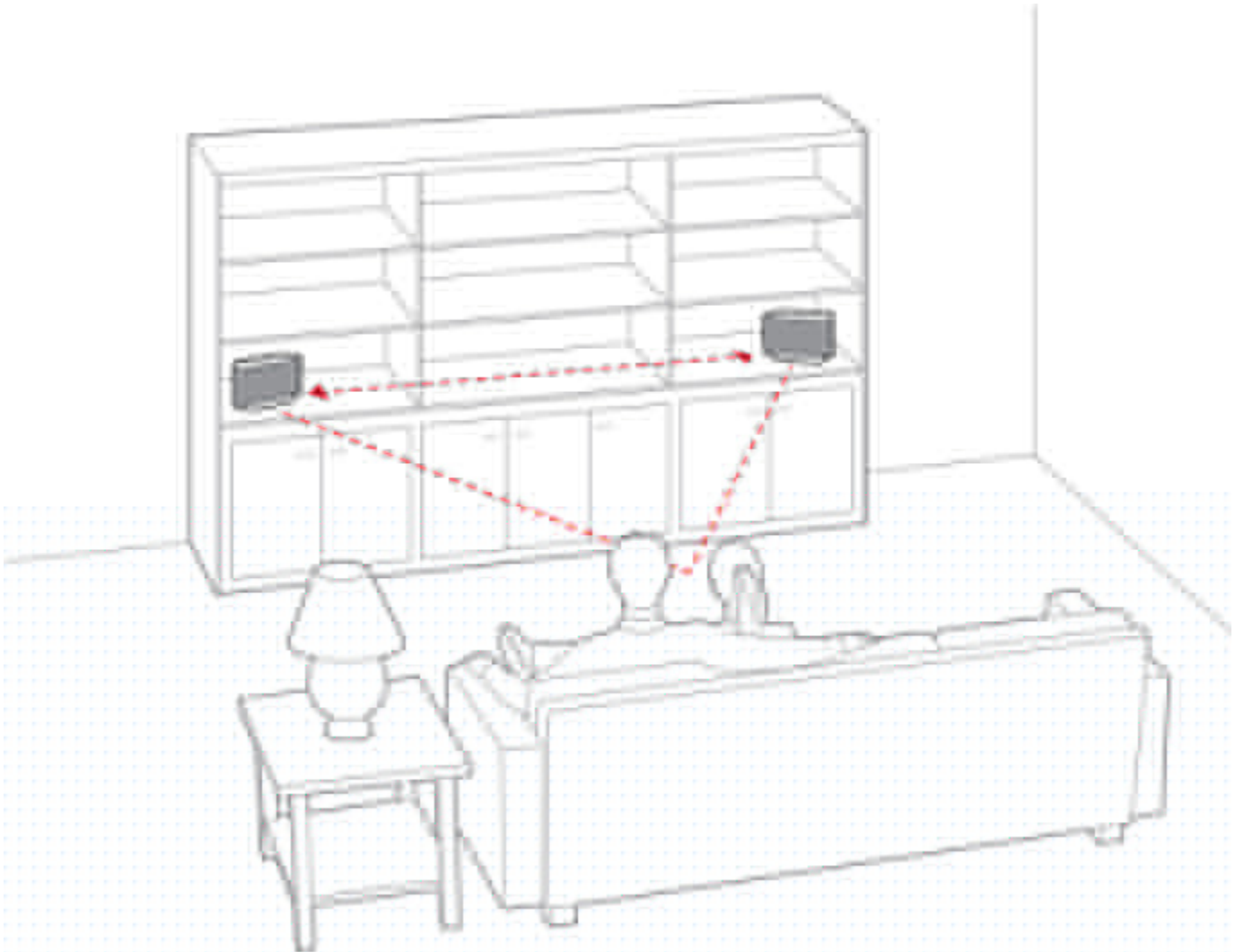

**Note:** The Stereo Pair setting is for use with PLAY:3 and PLAY:5 units only. Both Sonos components in the stereo pair must be the same.

## Using a handheld Sonos controller

1. Select **Settings** -> **Room Settings**.
2. Select one of the Sonos components you wish to create a stereo pair with (PLAY:3 or PLAY:5 only).
3. Select **Create Stereo Pair**, and touch **Next**.
4. Select the other unit you wish to pair.
5. Press the **Mute** button on the Sonos component you wish to become the left channel.

The units automatically connect to form a stereo pair.

**To separate a stereo pair:**

1. Select **Settings** -> **Room Settings**.
2. Select the stereo pair you wish to separate (the stereo pair appears with L + R in the room name.)
3. Select **Separate Stereo Pair**, and touch **Separate** to confirm.

## Using the Sonos Controller for Mac or PC

1. Choose one of the following:
  - Using the Sonos Controller for PC: Select **Settings** from the **Manage** menu.
  - Using the Sonos Controller for Mac: Select **Preferences** -> **Room Settings** from the **Sonos** menu.
2. Select one of the Sonos components (PLAY:3 or PLAY:5 only) you wish to pair from the **Room Settings for** drop-down list.
3. On the **Basic** tab, click **Create Stereo Pair** and then click **Next**.
4. Select the other unit you want to pair, and then click **Next**.
5. Press the **Mute** button on the Sonos component that will become the *left* channel.

**To separate a stereo pair:**

1. Choose one of the following:
  - Using the Sonos Controller for PC: Select **Settings** from the **Manage** menu.
  - Using the Sonos Controller for Mac: Select **Preferences** -> **Room Settings** from the **Sonos** menu.
2. Select the Sonos stereo pair you wish to separate from the **Room Settings for** drop-down (the stereo pair will appear with L + R in the room name).
3. On the **Basic** tab, click **Separate Stereo Pair**.
4. Click **Separate**.

## Playing Music

You can use any Sonos controller to make a music selection — simply touch to select from the **Music** menu on a handheld controller, or click to select from the **MUSIC** pane within the Sonos Controller for Mac or PC.

### Radio

Sonos includes a radio guide that provides immediate access to thousands of free Internet radio stations and broadcast programs. You can easily find radio from all over the world—music, news, and variety programming, including archived shows and podcasts.

To select an Internet radio station, simply select **Radio** and choose a station.

### Music services

A music service is an online music store or online service that sells audio on a per-song, per audiobook, or subscription basis. Sonos is compatible with several music services - you can visit our Website at [www.sonos.com/howitworks/music/partners](http://www.sonos.com/howitworks/music/partners)

for the latest list. (Some music services may not be available in your country. Please check the individual music service's Web site for more information.)

If you are currently subscribed to a music service that's compatible with Sonos, simply add your music service user name and password information to Sonos and you'll have instant access to the music service from your Sonos system.

1. To add a music service, touch **More Music** from the **Music** menu on your handheld controller.
2. Select the Sonos-compatible music service you would like to add.
3. Select **I already have an account**. Type your music service user name and password, and then touch **OK**. Your user name and password will be verified with the music service.

Once your credentials have been verified, this music service will display on the **Music** menu so any time you want to listen to this music service, simply touch **Music** menu, select the music service, and touch a selection.

Free music service trials are available in some countries. (Please check the individual music service's Web site for more information.) If there is a music service trial visible on your **More Music** menu, simply touch it to select. Touch **I'm new to [music service]**, and then follow the prompts to activate the music trial. After the trial period is up, you will need to subscribe to the music service to keep the music playing.

## Music folders

The Sonos system can play music from any computer or network-attached storage (NAS) device on your home network where you have shared music folders. During the setup process, you are guided through the process of accessing your shared music folders (such as your iTunes library). Over time, you may wish to add or remove folders from this list.

To make changes to your shared folders list, select the **Settings** menu from a handheld Sonos controller and then choose one of the following options:

- To add a new music folder to Sonos, select **Manage Music Library** -> **Music Library Setup** -> **Add New Share**.
- To remove a music folder, select **Manage Music Library** -> **Music Library Setup**. Touch the share you wish to remove and then select **Remove Share**.

The Sonos system indexes your music folders so you can view your music collection by categories (such as artists, albums, composers, genres, or tracks.) If you add new music to a folder that is already indexed, simply update your music index to add this music to your Sonos music library.

- To update your music index, select **Manage Music Library** -> **Update Music Index Now**. If you'd like your music index to update automatically each day, select **Schedule Music Index Updates** and then select a music index update time.

## Using Headphones

The SONOS PLAY:5 has a headphone jack you can utilize for private listening. The headphone jack is auto detecting—plug in a pair of headphones and the PLAY:5's built-in speakers automatically mute. When you unplug the headphones, the speakers automatically come back on.

When headphones are plugged in, a headphone icon  is visible on the Volume screen of a Sonos controller.

**Note:** If you don't hear sound coming from your PLAY:5, check to make sure there are no headphones plugged into the back of the unit.

1. Plug a pair of headphones into the headphone jack. (Sonos will automatically drop the volume level down to 25%.)
2. Put on your headphones and increase the volume to a comfortable listening volume.

**Note:** Long term exposure to music played at high volume through headphones can cause permanent hearing damage.

3. Remove the headphone jack from the back of the PLAY:5 when you are ready to resume listening through the built-in speakers.

## Using Line-In

You can connect an external source, such as a portable music player, to your SONOS PLAY:5. The device will be automatically detected as soon as you plug it in.

- To connect a portable music player, use the supplied 1/8" (3,5mm) stereo audio cable to plug a music player into the **Audio In** connection on the back of your S5.
- To connect another external source, such as a CD player, you can use a 1/8" (3,5mm) mini-stereo to RCA audio cable. Plug the mini-stereo end into the S5, and plug the RCA end into the audio outputs on the external device.

### Using a handheld Sonos controller:

- To play music from this line-in source, select **Line-In** from the **Music** menu, select the source, and select **Play Now**.
- To change the name of this device, select **Room Settings** from the **Settings** menu. Select the Sonos component this source is connected to, and then touch **Line-In Source Name**. Select a new name from the list, or type a unique name.
- To change the line-in level, select **Room Settings** from the **Settings** menu. Select the Sonos component this source is connected to, and then touch **Line-In Source Level**. Select a new level.

### Using the Sonos Controller for Mac or PC:

- To play music from this source select **Line-In** from the **MUSIC** pane, click ▼ next to the music source, and select **Play Now**.
- To change the settings for this device:
  - Select **Manage** -> **Settings** (PC) or **Sonos** -> **Preferences** -> **Room Settings** (Mac).
  - Select the Sonos component from the **Room Settings** for drop-down list.
  - Click the **Line-In** tab and update the settings.

A default (typical) line-in level is automatically assigned when you select a source name, but if the volume sounds too low, you can select a higher line level for this device. (You may experience sound distortion at higher volume levels if you set the level too high.)

For additional information on connecting audio devices, you can go to our Web site at <http://faq.sonos.com/cables>.

## Equalization Settings

You can easily change the sound settings (bass, treble, balance, or loudness) for a Sonos component.

1. Using a handheld controller, select **Settings** -> **Room Settings**.
2. Touch to select a room.

3. Select **Music Equalization**, and then drag your finger across the bass, treble, or balance sliders to make adjustments.
4. To change the Loudness setting, select **On** or **Off**. (The loudness setting boosts certain frequencies, including bass, to improve the sound at low volume.)

## Basic Troubleshooting

**Warning:** *Under no circumstances should the product be repaired by anyone other than an authorized Sonos repair center, as this will invalidate the warranty. Please contact Sonos Customer Support for more information. Do not open the system as there is a risk of electric shock.*

If a problem occurs, you can try the troubleshooting suggestions listed below. If one of these doesn't remedy the problem, or you are not sure how to proceed, please contact the Sonos Customer Support team and we'll be happy to help.

### Sonos component not detected during setup

A network or a firewall issue may be preventing the Sonos component from connecting to your Sonos system. If this is a wireless Sonos component, try moving the Sonos components closer together, or wire the component temporarily to see if the problem is related to wireless interference.

If you encounter this message when installing the first Sonos component (wired to your router), you can try the steps below to resolve this issue. If you are still experiencing problems, please contact Sonos Customer Support.

#### 1. Check the firewall

Firewall software installed on the computer may be blocking the ports that Sonos uses to operate. First, disable all your firewalls and try to connect again. If this resolves the problem, you should configure your firewall to work with the Sonos Controller for Mac or PC. Please go to our Web site at <http://faq.sonos.com/firewall> for additional information. If this does not resolve the problem, you can try step 2 below.

#### 2. Check the router

You can bypass your router's switch to determine whether there are any router configuration issues by connecting Sonos as depicted in the following illustration (note that the BRIDGE and the computer still have Internet access in this configuration):

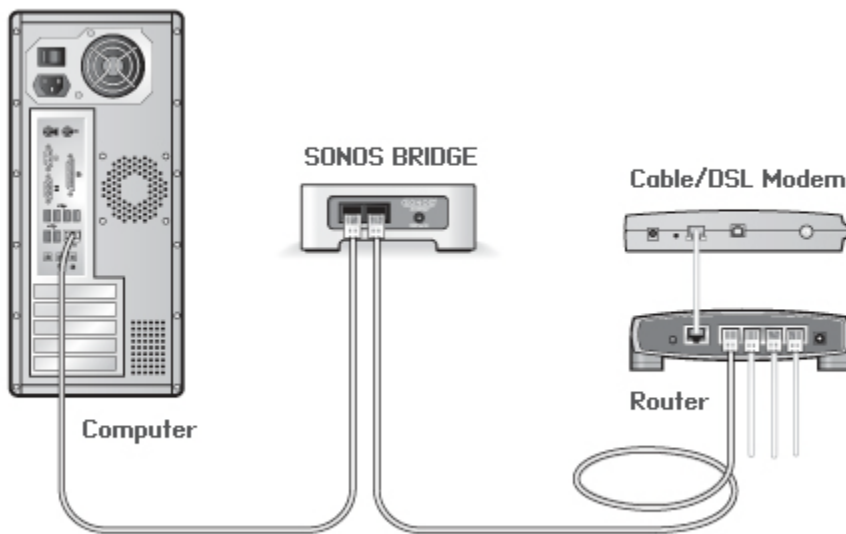

- Be sure that your cable/DSL modem is connected to the router's WAN (Internet) port.
- Temporarily remove any other components that are wired to your network.
- Connect an Ethernet cable from the computer directly to the back of the SONOS BRIDGE, and then connect another Ethernet cable from the BRIDGE directly to one of the LAN ports on your router.
- When you make a change to your network configuration, you may need to power cycle the BRIDGE by unplugging the power cord, and then plugging it back in.
- If you are not using a router, you can visit our Web site at <http://faq.sonos.com/norouter> for more information.

### 3. Check the wiring

Check the link/activity lights on both the router and the Sonos component. The link lights should be lit solid and the activity lights should be blinking.

- If the link lights are not lit, try connecting to a different port on your router.
- If the link lights still do not light, try connecting a different Ethernet cable.

## Not all rooms are visible

You are probably experiencing wireless interference. Change the wireless channel your Sonos system is operating on by following the steps below.

- Using a handheld Sonos controller: From the **Settings** menu, touch **Advanced Settings**, and then **Wireless Channel**. Choose another wireless channel from the list.
- Using the Sonos Controller for PC: Select **Settings** -> **Advanced Settings** from the **Manage** menu. On the **General** tab, select another wireless channel from the list.
- Using the Sonos Controller for Mac: Select **Preferences** -> **Advanced Settings** from the **Sonos** menu. On the **General** tab, select another wireless channel from the list.

It may take several seconds for the switch to take effect. If you have music playing, a short music dropout may occur during the wireless channel change.

## Important Safety Information

1. Read these instructions.
2. Keep these instructions.
3. Heed all warnings.
4. Follow all instructions.
5. Do not use this apparatus near water.
6. Clean only with dry soft cloth. Household cleaners or solvents can damage the finish on your Sonos components.
7. Do not install near any heat sources such as radiators, heat registers, stoves, or other apparatus that produce heat.
8. Protect the power cable from being walked on or pinched, particularly at plugs, convenience receptacles, and the point where they exit from the apparatus.
9. Only use attachments/accessories specified by the manufacturer.
10. Unplug this apparatus during lightning storms or when unused for long periods of time.
11. Refer all servicing to Sonos qualified service personnel. Servicing is required when the apparatus has been damaged in any way, such as power-supply cable or plug is damaged, liquid has been spilled or objects have fallen into the apparatus, the apparatus has been exposed to rain or moisture, does not operate normally, or has been dropped.
12. The Mains plug should be readily available to disconnect the equipment.
13. **Warning:** To reduce the risk of fire or electric shock, do not expose this apparatus to rain or moisture.
14. Do not expose apparatus to dripping or splashing and do not place objects filled with liquids, such as vases, on the apparatus.