



Sonos ZonePlayer 100

Product Guide

THIS DOCUMENT CONTAINS INFORMATION THAT IS SUBJECT TO CHANGE WITHOUT NOTICE.

No part of this publication may be reproduced or transmitted in any form or by any means, electronic or mechanical, including but not limited to photocopying, recording, information retrieval systems, or computer network without the written permission of SONOS, Inc.

SONOS, THE WIRELESS HI-FI SYSTEM, PLAY:3, PLAY:5 and all other Sonos product names and slogans are trademarks or registered trademarks of Sonos, Inc. SONOS Reg. U.S. Pat. & Tm. Off.

The SONOS PLAY:3 and PLAY:5 are protected by patents including: U.S. Patents US7,696,816 and US7,378,903. Other patents are pending.

The SONOS BRIDGE is protected by U.S. patent number D575,800.

The SONOS CONNECT is protected by U.S. patent numbers: D559,197 and D582,429.

The SONOS CONNECT AMP is protected by U.S. patent numbers: 7,378,903; 7,696,816; 7,792,311; D559,197; D575,801.

The SONOS CONTROL is protected by U.S. patent numbers: 7,571,014; 7,805,682; D559,197; D582,429.

Other patents are pending.

iPhone®, iPod®, iPad® and iTunes® are trademarks of Apple Inc., registered in the U.S. and other countries.

Windows® is a registered trademark of Microsoft Corporation in the United States and other countries.

Android® is a trademark of Google Inc.

MPEG Layer-3 audio decoding technology licensed from Fraunhofer IIS and Thomson.

SONOS uses MSNTP software, which was developed by N.M. Maclaren at the University of Cambridge.

© Copyright, N.M. Maclaren, 1996, 1997, 2000; © Copyright, University of Cambridge, 1996, 1997, 2000.

All other products and services mentioned may be trademarks or service marks of their respective owners.

© 2004-2011 by SONOS, Inc. All rights reserved.

The Sonos ZonePlayer 100

- The ZonePlayer 100 has a high-performance, built-in amplifier that can power large or small speakers, allowing you to enjoy superior audio quality in every room.
- The ZonePlayer 100 has a 4-port Ethernet switch to enable multiple direct connections to routers, computers, and other ZonePlayers.
- The ZonePlayer 100 has analog audio inputs with digital encoding so that music from an external audio source (such as a CD player or portable MP3 player) can be connected to one ZonePlayer, and played by all the other ZonePlayers in the system.

New to Sonos?

It takes just a few steps to get your Sonos system up and running. The steps below are fully explained in the Quick Start Guide packaged with your ZonePlayer 100 —

- Connect one Sonos component (BRIDGE, CONNECT:AMP, PLAY:3, PLAY:5, CONNECT, ZonePlayer 100) to your broadband router using an Ethernet cable (supplied).
- Place other Sonos components in the rooms of your choice.
- Install the software and follow the prompts to add the Sonos components and set up access to your music files.
- Add a Sonos controller to your music system.

See "Your Home Network" on page 2 to make sure your home network is ready for Sonos, and then follow the instructions on page 3. Once you've set up your music system, you can add additional Sonos components any time.

Adding to an existing Sonos system?

Sonos can be easily expanded room by room. If you are adding this ZonePlayer 100 to an existing Sonos system, you can turn directly to "Adding to an Existing Sonos System" on page 6.

Your Home Network

To play the digital music files stored on your computer, your computer network must meet the following requirements:

Network requirements

Important: Your network must have a high-speed Internet connection, as Sonos is designed to provide you with online software updates. Your Sonos system must be registered to receive these updates, so be sure to register during the setup process. We do not share your e-mail address with other companies.

- High-speed DSL/Cable modem, or fiber-to-the-home broadband connection for proper playback of Internet-based music services. (If your Internet service provider only offers Satellite Internet access, you may experience playback issues due to fluctuating download rates.)
- If your modem is not a modem/router combination and you want to take advantage of Sonos' automatic online updates, or stream music from an Internet-based music service, **you must install a router in your home network.** If you do not have a router, purchase and install one before proceeding.
 - If you are going to use a Sonos controller application on an Android™ smartphone, iPhone®, iPod Touch®, iPad® or other tablet, you may need a wireless router in your home network. Please visit our Web site at <http://faq.sonos.com/apps> for more information.
- Connect at least one Sonos component to your home network router using an Ethernet cable, and then you can add other Sonos components wirelessly.
- For best results, you should connect the computer or NAS drive that contains your personal music library collection to your home network router using an Ethernet cable.

Compatible operating systems

- Windows® XP and higher
- Macintosh® OS X

Note: Please visit our Web site at <http://faq.sonos.com/specs> for the latest system requirements, including supported operating system versions.

1-2-3 Setup

1 Connect Speakers and Apply Power

Important: Be sure to connect the red (+) and black (-) terminals from each speaker to the corresponding terminals on the ZonePlayer. Mismatching of polarities will result in weak central sound, and a distorted sense of sound direction.

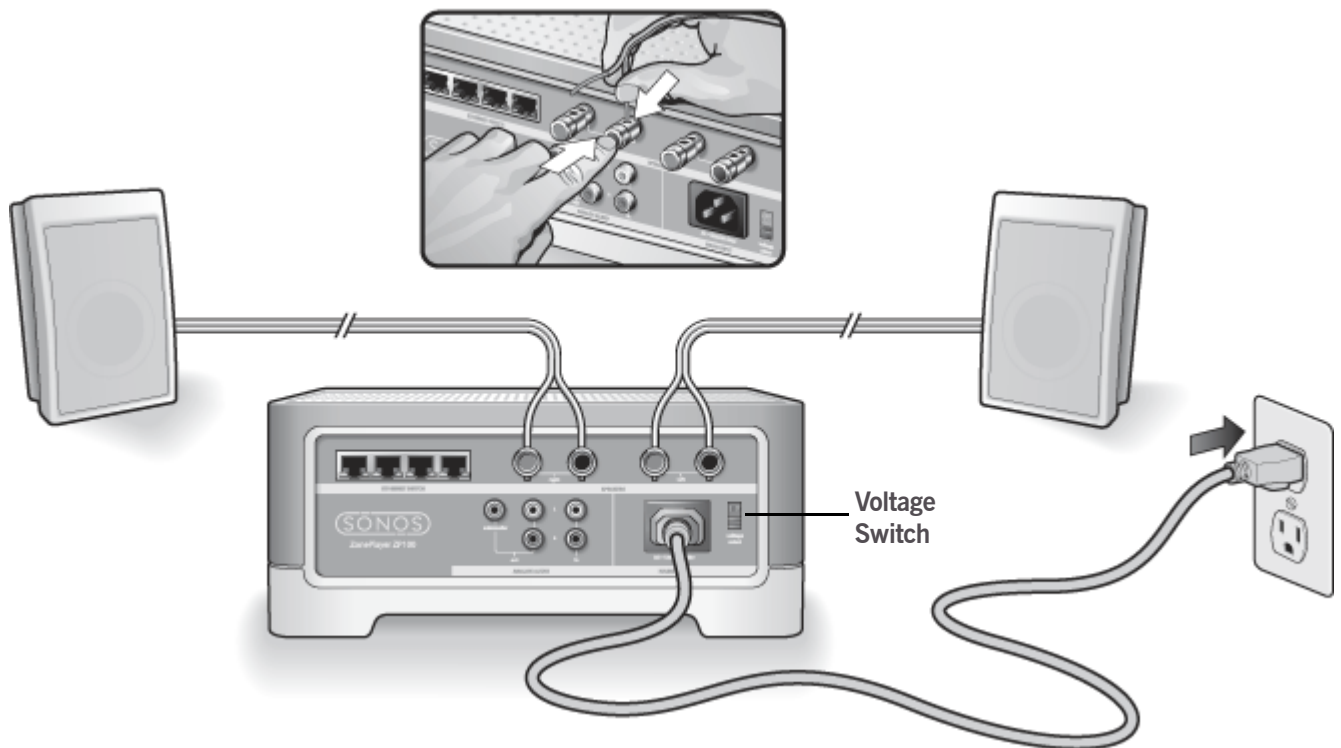

Speakers: Power rating should be at least 75W for 8 Ohm speakers and at least 150W for 4 Ohm speakers.

- Use your thumb or finger to firmly push the spring-loaded speaker connector post inward to reveal the connection hole.
- Insert the stripped end of the speaker wire into the hole, then release. Repeat for the other speaker connections.

Important Note: Make sure the voltage switch is set to the proper position for your household before plugging in your ZonePlayer ZP100.

- Attach the power cable and plug in your ZonePlayer.

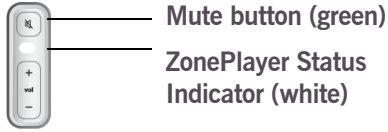

Proceed to step 2 when the Status indicator on the ZonePlayer's front panel flashes white and the Mute button flashes green.

2 Connect First ZonePlayer 100

Important: The first Sonos component you install must connect to your home network using a standard Ethernet cable (supplied). **If you prefer to use this ZonePlayer wirelessly, you can connect a SONOS BRIDGE to your router instead.**

Connect a standard Ethernet cable (supplied) from any of the four (4) Ethernet switch connectors on the back of your ZonePlayer to an open port on your router (see A in the diagram below). Do not connect the ZonePlayer directly to your cable or DSL modem unless your modem has a built-in router.

- If you don't have a router, go to <http://faq.sonos.com/norouter> for instructions.

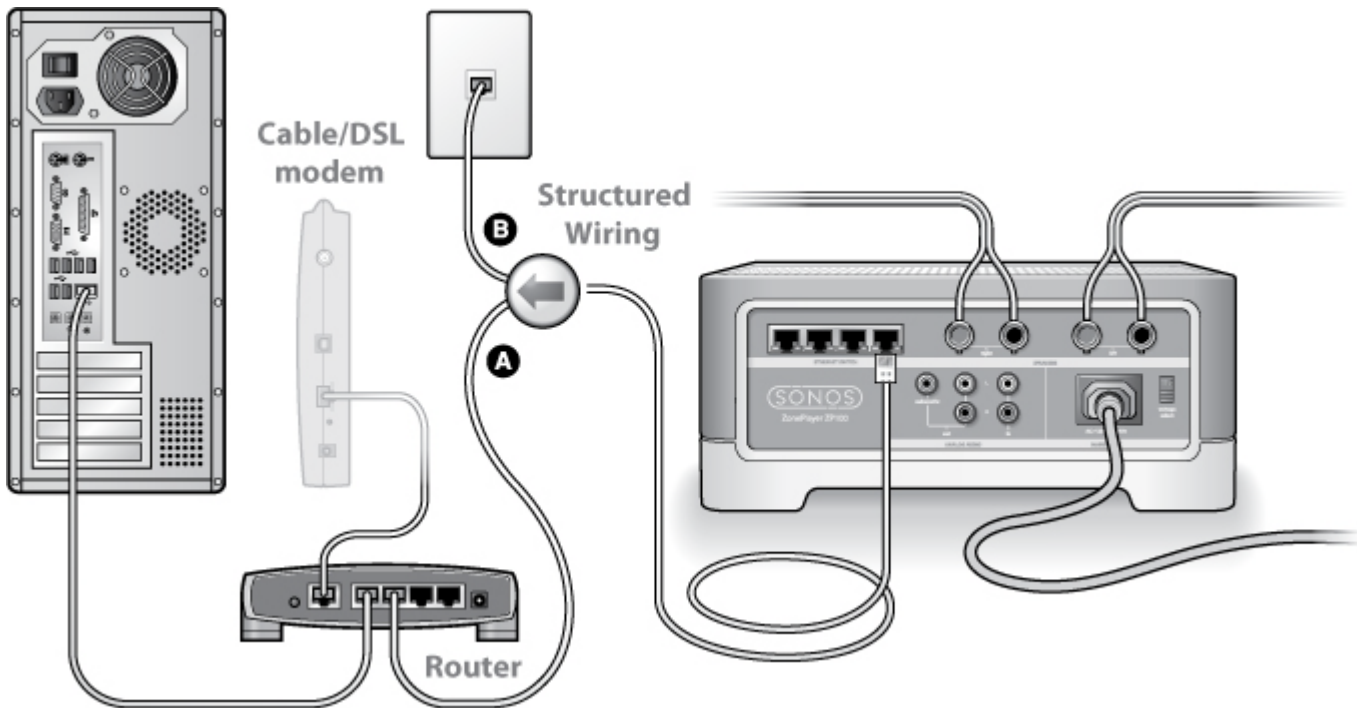

- If you don't have an open port on your router, you can disconnect your computer from the router and connect it to the ZonePlayer instead. Then connect the ZonePlayer into the router port the computer was previously plugged into.

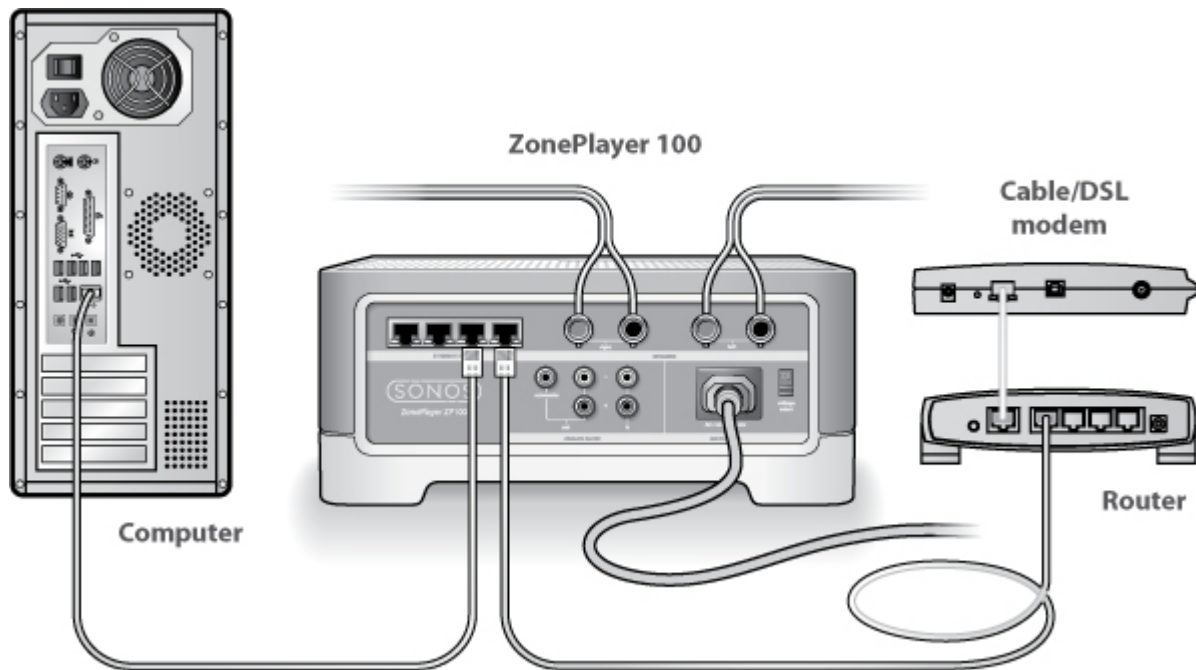

3 Install Software



- Insert the Sonos System Setup CD-ROM (included with your ZonePlayer), and follow the prompts to connect your ZonePlayer(s) and set up access to your music files.

Important: Firewall software such as Norton Internet Security™, McAfee™ Personal Firewall, Windows® Firewall, or Mac OS X Firewall, can block the operation of your Sonos Desktop Controller software. During installation, you may see prompts from your firewall software indicating that the Sonos application is attempting to perform certain operations. You should always allow full access to the Sonos application. You may also need to change the settings of your firewall software to ensure that Windows file sharing is not blocked. Please go to our Web site at <http://faq.sonos.com/firewall> for detailed instructions.

Now you're ready to add a Sonos controller to your Sonos system.

Sonos Controllers

You can use any Sonos controller with the Sonos ZonePlayer 100, including:

- The Sonos Controller for Android — Touch the **Market** button on your smartphone to download the free Sonos application from the Android Market™
- The Sonos Controller for iPhone or the Sonos Controller for iPad — Tap the **App Store** button on your iPhone, iPod touch or iPad to download the free Sonos application, or you can download the application from iTunes®. (If you download from iTunes, you will need to sync before you see the Sonos logo display on your device)
- The SONOS CONTROL or Sonos Controller 100
- The Sonos Controller for Mac or PC (install using the CD-ROM packaged with your Sonos component)

Sonos is always working on new ways to help you control the music any way you want. For the latest list of Sonos controllers, please visit our Web site at www.sonos.com/products.

Adding to an Existing Sonos System

Once you've got your Sonos system set up, you can easily add more Sonos components any time (up to 32 zones).

If your house has structured (built-in) wiring, you can make a wired connection to the additional Sonos components. If you don't, our built-in wireless technology is ideal for you.

Important: If you are replacing the Sonos component that is currently attached to your router, first add the new Sonos ZonePlayer 100 to your music system (steps below.) You can then unplug the wired Sonos component from your router, replace it with the ZonePlayer 100, and move the original Sonos component to a new location.

1. Attach desired speakers to the ZonePlayer 100 (power rating should be at least 75W for 8 Ohm speakers and at least 150W for 4 Ohm speakers.) If you need help with this step, see page 3.
2. Attach the power cord and plug in the ZonePlayer 100 — make sure the Voltage switch on the back is set to the proper position for your country before applying power.
3. Choose one of the following options:
 - Using a handheld Sonos Controller, select **Settings** -> **Add a Zone** from the **Music Menu** and follow the on-screen prompts to add this component to your Sonos system.
 - Using the Sonos Controller for Mac or PC, select **Zones** -> **Add a Zone** and follow the prompts to add this component to your Sonos system.

Playing Music

You can use any Sonos controller to select music— simply touch to select from the **Music Menu** on a handheld controller, or click to select from the **Music Library** pane within the Sonos Controller for Mac or PC.

Radio

Sonos includes a radio guide that provides immediate access to thousands of free Internet radio stations and broadcast programs. You can easily find radio from all over the world—music, news, and variety programming, including archived shows and podcasts.

To select an Internet radio station, simply touch **Radio**.

Music services

A music service is an online music store or online service that sells audio on a per-song, per audiobook, or subscription basis. Sonos is compatible with several music services - you can visit our Website at www.sonos.com/howitworks/music/partners for the latest list. (Some music services may not be available in your country. Please check the individual music service's Web site for more information.)

If you are currently subscribed to a music service that's compatible with Sonos, simply add your music service user id and password information to Sonos and you'll have instant access to the music service from your Sonos system.

1. To add a music service, touch **More Music**.
2. Select the Sonos-compatible music service you would like to add.
3. Select **I already have an account**. Type your music service user name and password, and then touch **Done**. Your user name and password will be verified with the music service.

Once your credentials have been verified, this music service will display on the Music Menu so any time you want to listen to this music service, simply touch **Music Menu**, select the music service, and touch a selection.

Free music service trials are available in some countries. (Please check the individual music service's Web site for more information.) If there is a music service trial visible on your **More Music** menu, simply touch it to select.

Touch **I'm new to [music service]**, and then follow the prompts to activate the music trial. After the trial period is up, you will need to subscribe to the music service to keep the music playing.

Music folders

Sonos can play music from any computer or network-attached storage (NAS) device on your home network where you have shared music folders. During the setup process, you are guided through the process of accessing these shared music folders. Over time, you may wish to add or remove folders from this list.

- To add new music folders to Sonos, touch **Settings** -> **Music Library Management** -> **Music Library Setup** -> **Add New Share**.
- To remove music folders, touch **Settings** -> **Music Library Management** -> **Music Library Setup**. Touch the share you wish to remove and then select **Remove Share**.

Sonos indexes your music folders so you can view your music collection by categories (such as artists, albums, composers, genres, or tracks.) If you add new music to a folder that is already indexed, simply update your music index to add this music to your Sonos music library.

To update your music index, touch **Settings** -> **Music Library Management** -> **Update Music Index Now**. If you'd like your music index to update automatically each day, select **Schedule Music Index Updates** and then select a music index update time.

Using Line-In

You can easily stream an external source such as a CD player or portable music player through your Sonos system using the audio-in connections on your Sonos ZonePlayer 100. The device will be automatically detected as soon as you plug it in.

- Use a standard RCA cable to plug an external source like a CD player into the analog **Audio In** connections on the back of your ZonePlayer 100.
- **If you are connecting a portable music player** to the ZonePlayer 100, you will need a 1/8 inch mini-stereo to RCA audio cable instead. Plug the mini-stereo end into the portable device and the RCA end into the **Audio In** connection on the ZonePlayer 100.

Using a handheld Sonos Controller:

- To play music from this line-in source, select **Line-In** from the **Music** menu, select the source, and select **Play Now**.
- To change the name of this device, select **Settings** -> **ZonePlayer Settings**. Select the Sonos component this source is connected to, and then touch **Line-In Source Name**. Select a new name from the list, or type a unique name.
- To change the line-in level, select **Settings** -> **ZonePlayer Settings**. Select the Sonos component this source is connected to, and then touch **Line-In Source Level**. Select a new level.

Using the Sonos Controller for Mac or PC:

- To play music from this line-in source, select the **Line-In** tab from the **Music Library**, select the source, and click **Play Now**.
- To change the settings for this device, select the **Line-In** tab from the **Music Library**, select the source, and click **Setup**. Select the **Line-In** tab to make changes.

A default (typical) line-in level is automatically assigned when you select a source name, but if the volume sounds too low, you can select a higher line level for this device. (You may experience sound distortion at higher volume levels if you set the level too high.)

Line-in encoding settings

When you have line-in music sources attached to a Sonos component, line-in encoding determines how the Sonos system will encode the data coming in from these sources. For multi-room audio, we recommend using the **Compressed** setting. For the highest quality sound, you can select **Uncompressed** encoding, but this selection requires more network bandwidth than compressed audio. For TV or DVD audio, we recommend using the **Uncompressed** setting.

To change the line-in encoding setting, select one of the following options:

- Using a SONOS CONTROL or a Controller 100, select **Settings** -> **Advanced Settings** -> **Line-In Encoding**.
- Using the Sonos Controller for Mac or PC, select **File (PC)** or **Sonos (Mac)** -> **Preferences** and then click the **Advanced** tab.

For additional information on connecting audio devices, you can go to our Web site at <http://faq.sonos.com/cables>.

Using Line-Out

You can easily connect your home theater, stereo, or powered speakers to a ZonePlayer ZP100.

To connect to a home theater

If you have analog inputs on your receiver, use a standard RCA audio cable to connect the ZonePlayer ZP100's analog audio output to the audio inputs on your home theater receiver. Select the proper input channel on your home theater system.

Line-out level setting

If you want to control the volume exclusively from your home theater, change the line-out level on this ZonePlayer to **Fixed**. (When the line-out level is set to **Variable**, you can use the Sonos Controller to control the volume on the line-out connection.)

To change the line-out level setting, choose one of the following options:

- Using the Sonos Controller, from the **Music** menu, select **System Settings**. Select **ZonePlayer Settings**, and use the scroll wheel to highlight the ZonePlayer attached to your home theater. Select **Line-Out Level**, and choose **Fixed**.
- Using the Desktop Controller software, select **Set Up Zones** from the **Zones** menu. Select the ZonePlayer attached to your home theater, and then click **Settings**. Click the **Line-Out** tab, and choose **Fixed**.

Important: When you change the line-out level to Fixed on a ZonePlayer, you will not be able to adjust the volume or the equalization settings using your Sonos Controller.

To connect to your computer

You will need a stereo mini to RCA Y-adapter audio cable (one 1/8-inch stereo miniplug to dual RCA male connectors) to connect the ZonePlayer's analog audio output to the computer's audio input.

To connect to powered speakers

You may need a Y-adapter audio cable (one 1/8-inch stereo miniplug to dual RCA male connectors) to connect the computer's speakers to the audio outputs on the ZonePlayer. If your speakers have a male 1/8-inch stereo plug, you can use a Y-adapter audio cable (one 1/8-inch Female connector to dual RCA male connectors).

For additional information on connecting audio devices, you can go to our Web site at <http://faq.sonos.com/cables>. For additional guidance on the use of this feature, please go to the online help system included with your Desktop Controller software.

ZonePlayer ZP100 Front



On/Off

- Using a Sonos controller, select Pause All from the Zone menu.
- Using the Desktop Controller software, select Pause All from the Play menu.

Your Sonos system is designed to be always on; the system uses minimal electricity whenever it is not playing music. To stop streaming music in all zones, you can use the **Pause All** feature.

ZonePlayer status indicator

- Flashes white when powering up or connecting to your Sonos system.
- Solid white when powered up and connected to your Sonos system (normal operation).

Indicates the current status of the ZonePlayer. When the ZonePlayer is in normal operation, you can turn the white status indicator light on and off. For additional information, see the online help system included with your Desktop Controller software. For a complete list of status indications, please go to <http://faq.sonos.com/led>.

Mute button

- Lights solid green when sound is muted.
- Flashes green rapidly when household mute or unmute is about to take place.
- Flashes green slowly when ZonePlayer is connecting to your music system.

To mute/unmute this ZonePlayer: Press the **Mute** button to mute or unmute this ZonePlayer.

To mute/unmute all ZonePlayers: Press and hold the **Mute** button for 3 seconds to mute all ZonePlayers in your household. Press and hold for 3 seconds to unmute all ZonePlayers.

Volume up (+)

Volume down (-)

Press these buttons to adjust the volume up and down.

ZP100 Rear Panel Connectors

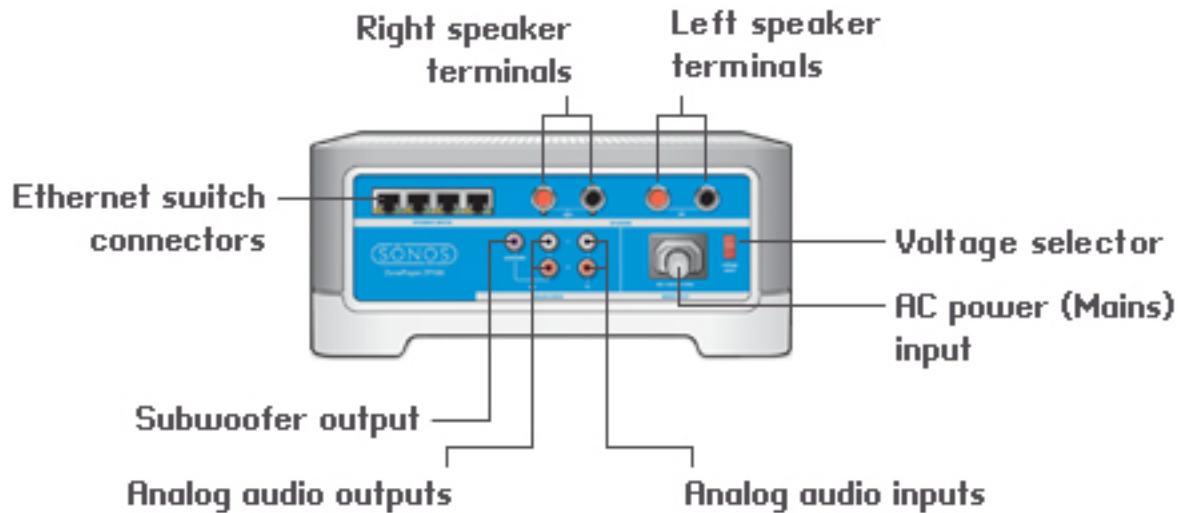

Ethernet switch connectors (4)

Use Category 5 Ethernet cable to connect to a router, computer, or additional network device such as a network-attached storage (NAS) device.

LED indicators:

- Green (link connection)
- Flashing Yellow (network activity)

Right speaker terminals

Use high-quality speaker wire to connect the right speaker to the ZonePlayer.

Left speaker terminals

Use high-quality speaker wire to connect the left speaker to the ZonePlayer.

Voltage select

115V/230V

Select the appropriate voltage setting for your country.

AC power (mains) input

Use the supplied power cord to connect to power outlet.

Analog audio out (fixed/variable)

You may use a standard RCA audio cable to connect the audio inputs on a separate audio component such as an amplifier or your home theater receiver, to the ZonePlayer's analog audio outputs.

Analog audio in

You may use a standard RCA audio cable to connect the ZonePlayer's analog audio inputs to the audio outputs from a separate audio component, such as a CD player or a portable music player.

Subwoofer output

Note: If you disconnect your subwoofer, make sure to also disconnect the subwoofer's cable from the ZonePlayer output.

You may connect a powered subwoofer to this output using a standard RCA cable. The system will detect when a cable is connected to the subwoofer output and adjust the crossover frequency automatically.

Basic Troubleshooting

Warning: Under no circumstances should the product be repaired by anyone other than an authorized Sonos repair center, as this will invalidate the warranty. Please contact the Sonos Customer Service Center to locate an authorized repair center in your area. Do not open the system as there is a risk of electric shock.

If a problem occurs, you can try the troubleshooting suggestions listed below. If one of these doesn't remedy the problem, or you are not sure how to proceed, please contact the Sonos Customer Service Center and we'll be happy to help.

- **Web site**

Visit our Web site at www.sonos.com/support. There you can visit our Forums, browse our Frequently Asked Questions (FAQ) pages, or request assistance.

- **Telephone**

Visit our Web site at www.sonos.com/support and click **Phone Support** to find the correct telephone number for your country.

ZonePlayer not detected during setup

A network problem may be preventing the ZonePlayer from associating with the Desktop Controller software. If this is a wireless ZonePlayer, try moving the your Sonos components closer together, or wire the ZonePlayer temporarily to see if the problem is related to wireless interference.

If you encounter this message when installing the first wired Sonos component, you can try the steps below to resolve this issue:

1. **Check the firewall**

Firewall software installed on the computer may be blocking the ports that Sonos uses to operate. First, disable all your firewalls and try to connect again. If this resolves the problem, then you should configure your firewall to work with the Sonos music system. You can go to our Website at <http://faq.sonos.com/firewall> for additional information. If this does not resolve the problem, you can try step 2.

2. Check the router

You can bypass your router's switch to determine whether there are any router configuration issues (note that the ZonePlayer and the computer still have Internet access in this configuration):

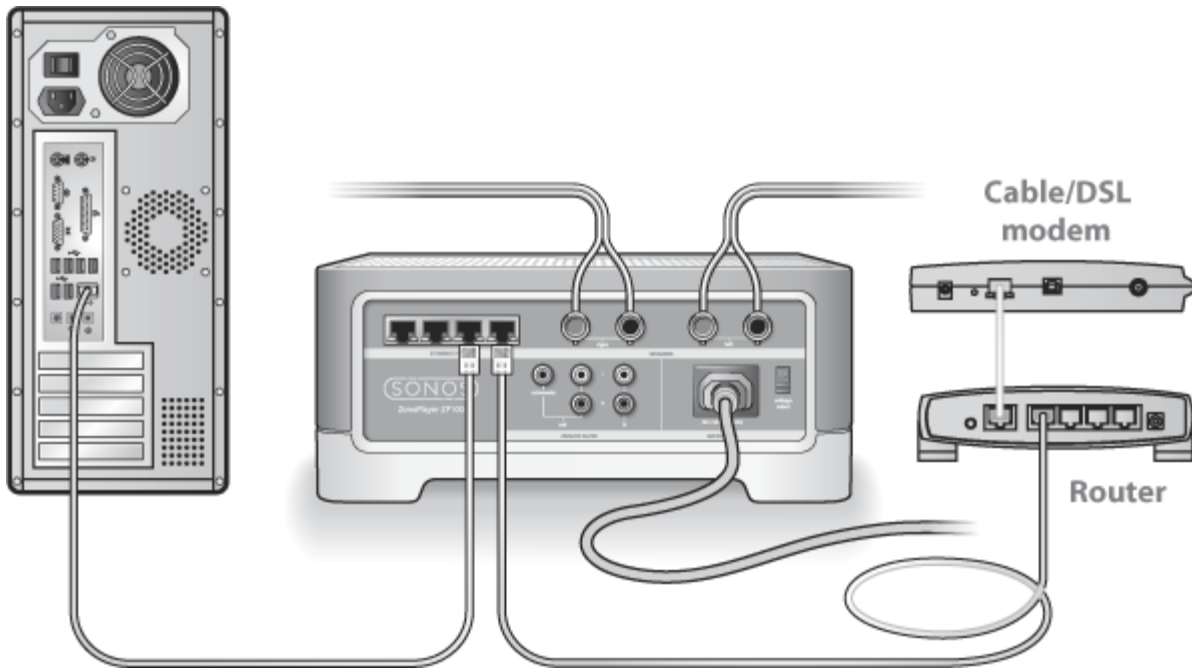

- Be sure that your cable/DSL modem is connected to the router's WAN (Internet) port.
- Temporarily remove any other components that are wired to your network.
- Connect an Ethernet cable from the computer directly to the back of the ZonePlayer, and then connect another Ethernet cable from the ZonePlayer directly to one of the LAN ports on your router.
- When you make a change to your network configuration, you may need to power cycle the ZonePlayer by unplugging the power cord, and then plugging it back in.
- If you are not using a router, see <http://faq.sonos.com/norouter>.

3. Check the wiring

Check the link/activity lights on both the router and the ZonePlayer. They should be green, and there should be blinking activity lights.

- If the green link lights are not lit, try connecting to a different port.
- If the link lights still do not light, try connecting a different Ethernet cable.

If you are still experiencing problems, please contact the Sonos Customer Service Center.

When adding the handheld Sonos Controller, it fails to detect the ZonePlayer(s)

Wireless interference or a network problem may be preventing the Controller from joining your Sonos Wireless HiFi System.

1. Verify that this is not a DHCP or network problem.

- Disconnect the Ethernet cables from the back of the ZonePlayer so that it is not connected to your network.
- Unplug the ZonePlayer's power cord and then plug it back in.
- Once the status indicator light stops blinking white, try adding your Controller again.

If it works, your router's DHCP server may have run out of available IP addresses to assign to the Controller. In most cases you can log into your router by typing `http://192.168.1.1` into your browser's address line (the IP address of your router may be different). Check the DHCP settings and increase the number of IP addresses available in the DHCP scope.

If your Controller still does not recognize the ZonePlayer after completing this step, you can try step 2.

2. Turn off any 2.4GHz cordless phones.

Some 2.4GHz cordless telephones can cause wireless interference. If turning off your 2.4GHz cordless phone resolves the problem, you should consider switching to a 5.8GHz or 900Mhz phone (or change the wireless channel your Sonos system is operating on - see step 4 below.)

3. Put 108 Mbps wireless routers into 54 Mbps mode.

Sonos cannot function properly when a router is operating in "turbo" mode. In order to double the speed from 54 Mbps to 108 Mbps, the router goes into a wide bandwidth mode which utilizes most of the 2.4 GHz spectrum that the FCC has set aside for 802.11b/g devices. This means that interference (RF noise) will occur with any other 2.4 GHz device that is not operating on the same channel as the 108 Mbps device (usually channel 6). While it is possible to put all of your wireless devices on channel 6, it is unwise. The devices will have to compete for available bandwidth, and your entire Wi-Fi network will become sluggish and bogged down.

4. Change the wireless channel your Sonos system is operating on.

- Using the Desktop Controller software for Windows: From the **File** menu, select **Preferences**. Click the **Advanced** tab, and then select another wireless channel from the **Wireless Channel** list.
- Using the Desktop Controller software for Macintosh: From the **Sonos** menu, select **Preferences**. Click the **Advanced** tab, and then select another wireless channel from the **Wireless Channel** list.

It may take several seconds for the switch to take effect. If you have music playing, a short music dropout will occur during the wireless channel change.

Important Safety Information

1. Read these instructions.
2. Keep these instructions.
3. Heed all warnings.
4. Follow all instructions.
5. Do not use this apparatus near water.
6. Clean only with dry soft cloth.
7. Do not block any ventilation openings. Install in accordance with the manufacturer's instructions.
8. Do not install near any heat sources such as radiators, heat registers, stoves, or other apparatus that produce heat.
9. Do not defeat the safety purpose of the grounding-type plug. A grounding-type plug has two blades and a third grounding prong. The third prong is provided for your safety. If the provided plug does not fit into your outlet, consult an electrician for replacement of the obsolete outlet.
10. Protect the power cable from being walked on or pinched, particularly at plugs, convenience receptacles, and the point where they exit from the apparatus.
11. Only use attachments/accessories specified by the manufacturer.
12. Unplug this apparatus during lightning storms or when unused for long periods of time.
13. Refer all servicing to qualified service personnel. Servicing is required when the apparatus has been damaged in any way, such as power-supply cable or plug is damaged, liquid has been spilled or objects have fallen into the apparatus, the apparatus has been exposed to rain or moisture, does not operate normally, or has been dropped.
14. The Mains plug should be readily available to disconnect the equipment.
- 15.Warning:** To reduce the risk of fire or electric shock, do not expose this apparatus to rain or moisture.
16. Do not expose apparatus to dripping or splashing and do not place objects filled with liquids, such as vases, on the apparatus.

Important: Household cleaners or solvents can damage the finish on your ZonePlayers or Controllers. Clean only with a dry soft cloth.